



PREMIUM line

Safety storage cabinets in modern design



Type 90

Safety storage cabinets
with folding doors



Welcome to DÜPERTHAL, Welcome to the Original!

As a leading German quality and technology enterprise, we set the standards when it comes to designing system solutions for process-optimised storage of chemicals and hazardous materials. All of our products and solutions are tailored specifically to meet your requirements. Aside from maximum safety, they offer the highest levels of effectiveness and efficiency – even in situations where there is no risk of fire. We are therefore providing you, as the customer, with reassurance. This is what we, as a family-run company, stand for. The original is what we stand for.



Safeguarding your values –

Since 1973, and into the future

For more than forty years, we have been setting standards in our industry. As our customer, you benefit from our technological and commercial know-how: expertise that has been demonstrated in numerous reference projects for renowned international organisations. We constantly raise the bar, continuing to enhance our safety solutions so that we can help safeguard your values, also in the future.

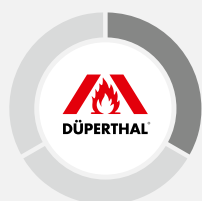

Delivering the perfect system solution –

Customised designs, if needed, TÜV-certified prior to installation.

In addition to standard products of exceptional quality, we are the only company on the market to also offer customised, TÜV-certified system solutions that do not require acceptance on delivery. From consultation to components, installation and routine maintenance – we always strive to offer the best possible added value from the perspective of technical safety and operational management.



Helping you stay one step ahead –

With service and personal communication

By choosing a DÜPERTHAL solution, you are also gaining a strong, proactive partner. Our aim is to always stay one step ahead. All our products and solutions exceed the requirements laid down by certification programmes. The same applies to our work with you. We openly discuss challenges and propose improvements, helping you to always identify the ideal solution.

Our Commitment for your Safety



Ultimate user-friendliness is what you can expect from the original PREMIUM line – Type 90 from DÜPERTHAL. Reliable safety storage cabinets with 90-minute fire resistance for storage of hazardous substances in the workplace in accordance with TRGS 510. Benefit from greater safety and increased convenience in the laboratory.

» Outstanding quality	6
» Maximum fire resistance – Type 90	7
» For flexible use	8
» Individual solutions	9
» All-round service	10
» Wide range of colours	11
» Protection against unauthorised access	12
» Versatile optional extras	13
» Safety and functionality	14
» PREMIUM standard – Type 90	16
» PREMIUM SL – Type 90	22
» PREMIUM vario – Type 90	36
» Optional extras for added safety	42

Solved internally, verified externally and independently

Quality comes above all else at DÜPERTHAL. This is confirmed by the quality marks of approval awarded to each of our safety storage cabinets and to us as a company, thanks to our comprehensive quality management system as per DIN EN ISO 9001. A basic prerequisite here is that the manufacture of the safety storage cabinets is not only subject to our own in-house inspections but also undergoes continuous external monitoring by accredited test institutes.



Occupational health and safety

OSHA / EU-OSHA

Protection of employees and the environment is of the utmost importance when working with hazardous substances. For this reason, the DÜPERTHAL PREMIUM line complies with the requirements of the Agency for Safety and Health at Work (OSHA, EU-OSHA).

Certified safety of the highest level included

- » Type testing in accordance with DIN EN 14470-1 by accredited test institutes (TÜV Süd, ift Rosenheim).
- » TÜV testing in accordance with DIN EN 14727 (laboratory furniture standard).
- » Type 90 classification in accordance with DIN EN 14470-1.
- » High Quality mark of approval for superior design, user-friendliness and increased lifetime.
- » GS/CE mark.



Reliable fire protection behind easy-moving folding doors

Standard laboratory cabinets do not protect the stored working materials from the external influences of heat. This can cause substances to react in the event of fire, resulting in personal and material damage.



90 minutes of fire resistance

The type 90 fire- and explosion-proof safety storage cabinets from DÜPERTHAL can be relied upon to resist fire for 90 minutes. In a critical situation, this leaves sufficient time for evacuation as well as a safe margin for taking resolute action to combat the fire.

Functional and safe

Safety is one thing, but functionality need never be compromised with the DÜPERTHAL PREMIUM line. With its PREMIUM line, DÜPERTHAL combines laboratory-standard storage with maximum fire resistance, naturally type-tested in accordance with DIN EN 14470-1 and laboratory furniture standard DIN EN 14727. Extremely smooth, practical folding doors and a wealth of added features create the ideal conditions in which to manage any individual task both safely and efficiently.

For flexible use

Maximum safety in all areas

The handling of hazardous substances is subject to stringent regulations – for good reason. DÜPERTHAL can help you to meet all the relevant requirements whilst at the same time optimising your procedures. Our diverse range of products offers you flexible solutions with which to design your laboratory and workspace to your own specifications. Whether you require 90-minute fire resistance, refrigerated media storage or a combined solution for storing flammable hazardous substances with other chemicals, we can help you to create working areas that offer full compliance with all the legal and technical requirements. During the entire process, DÜPERTHAL's qualified professionals are always on hand to provide you with advice.



Safe storage for flammable substances

By guaranteeing 90 minutes of fire-resistant and explosion-proof storage, the Type 90 safety storage cabinets from DÜPERTHAL comply in all respects with the requirements of the Technical Rules for Hazardous Substances for storing flammable liquids. However, the following is also still applicable: Different substances may only be stored together if their joint storage does not increase the respective risks. Safety storage cabinets and their safety-relevant features thus may not suffer any damage. In response to complex storage requirements, including combined storage, DÜPERTHAL therefore offers solutions such as the hazardous substances centre. We are always glad to assist you with solutions that can optimise your storage facilities. We help you to select suitable safety storage cabinets and optimised accessories, such as exhaust air systems and other extras that facilitate your daily work.

System solutions, tailored to your requirements

DÜPERTHAL offers system solutions for process-optimised storage of chemicals and hazardous substances in scientific research, development and production. Our goal is to accommodate your individual requirements in customised solutions. This is why you can expect not only remarkable certified products, but also outstanding service. Our team will help you to improve your work processes and to integrate our products in the best possible way so as to considerably enhance your safety.



Varied product range

With all our solutions, you have a choice between the standard product on the market and highly customised packages with a variety of fitted features. Professional advice and comprehensive service are always guaranteed.

DÜPERTHAL – constant reassurance

During our entire cooperation, we will offer you the unique DÜPERTHAL service. Starting with the project planning and technical product advice up to the delivery of the product itself, we will always be at your side.



Always at your service

Specialist carrier with checklist

Safety starts with the delivery of the product. Our specialist carrier works according to a detailed checklist and therefore ensures that our products are professionally installed in their final place of use.

Service agreement – the clever option

With a service agreement, we offer you the full service including maintenance and repair of your safety storage cabinets. Additionally, we will extend the manufacturer's guarantee to cover the contract period of the service agreement. The first inspection within the scope of a service agreement is free of charge. The first inspection within the scope of a service agreement is free of charge.



„Through regular maintenance within the scope of a service agreement, we guarantee the safety of your DÜPERTHAL safety storage cabinets for many years.“

Tommy Fittkau, Manager Technical Service,
Quality Management

Eye-catcher or inconspicuous storage?

PREMIUM line cabinets are available in a variety of colours to suit the surroundings, personal preferences and internal requirements. The standard colour for the carcass is light grey (RAL 7035). The folding doors are available in zinc yellow (RAL 1018) or light grey (RAL 7035). In addition to these colours and the ones depicted below, it is also possible to order customised shades.



Golden yellow
RAL 1004

Light grey
RAL 7035

Zinc yellow
RAL 1018

Pure white
RAL 9010

Locking systems for even greater safety

Only authorised personnel should have access to the PREMIUM line safety storage cabinet. After all, training in the handling and use of the materials therein is a requirement. Select the locking system that best suits your operational needs – guaranteeing maximum safety in the storage of dangerous chemicals.



Alternatives for secure access control

Cylinder lock (basic configuration)

All PREMIUM line models are fitted with a cylinder lock as a standard.

Integration into locking systems

Profile half-cylinder locks are optionally available for integration into existing locking systems.

Access with RFID card for intelligent protection against unauthorised access

The PREMIUM line is ideal for use with MPS (Modular Protection System), i. e. the RFID user card with MPS-1 can be used to unlock the doors.

Individual protection from danger

Safety has many aspects: this is why the PREMIUM line offers a flexible storage space for different storage containers in addition to the usual 90 minutes of fire resistance for flammable substances. A wide range of accessories and optional extras guarantee that the safety storage cabinets can be adapted to any situation.



Everything stored safely

Pipe penetrations

We can arrange for variable, reclosable penetrations for stainless steel pipes, cables and tubing up to a diameter of 28 mm to be incorporated in the cabinet roof or side panels, as needed. Flush-mounted penetrations can also be supplied.

Equipotential bonding

As a standard feature of the PREMIUM line, equipotential bonding saddles are incorporated in the cabinet roof for direct earthing connection as per TRBS 2153.

Locker

The additionally available locker is separately safeguarded by an access barrier and is screwed directly onto the safety storage cabinet.

Exhaust air systems

Exhaust air systems help to lessen the risk of explosion in the working area. An additionally available exhaust air monitoring unit (also with optional ventilator) emits an alarm if the system fails. A connection socket (NW 75) on the cabinet roof facilitates simple connection to the exhaust air system.

Safety and functionality



PREMIUM line safety storage cabinets are the ideal solution for safe and efficient storage of hazardous materials, even in confined working environments. The unique, pneumatic folding doors move with ease and save on space, thereby enhancing both the safety and comfort of working in the laboratory.

Focus on functionality

- 1** Extremely easy-moving folding doors, either with classic or one-hand operation, take up much less room and are therefore particularly suitable for laboratories where space is restricted.
- 2** The pneumatically powered doors mean that they can be easily opened with one hand, without external force.
- 3** All doors have an integrated arrest system, allowing containers to be removed from the cabinet and replaced with both hands.
- 4** The recessed base is an ergonomic solution that guarantees stability.
- 5** In case of fire, a thermocouple ensures that the doors are closed automatically. The cabinet doors are self-closing thanks to the closure control system.

Further features

- 6 Fumes that are hazardous to the health are extracted from above the bottom tray and from every level of the cabinet. In addition, the ventilation shut-off valves of the safety storage cabinet are easy to inspect visually.
- 7 For avoidance of ignition hazards, all PREMIUM line cabinets are equipped with equipotential bonding saddles on the cabinet roof for earthing connection as per TRBS 2153.
- 8 Ease of operation is enhanced thanks to the ergonomic position of the lock at handle height and a locking cylinder integrated in the door.
- 9 The cabinet is easy to manoeuvre thanks to the construction of the base, enabling transportation with a pallet truck, for instance.





PREMIUM standard – Type 90

Discover our space-saving solution for storing larger quantities of hazardous materials: the PREMIUM standard from DÜPERTHAL with 90-minute fire protection. Explore the versatility and comfort offered by the PREMIUM standard range.



PREMIUM standard XL – V1



PREMIUM standard XL – V2



PREMIUM standard M



PREMIUM standard ML

Interior fittings:

- » Shelves, bottom trays and perforated sheet inserts either in sheet steel or stainless steel.

Construction:

- » Folding doors of powder-coated sheet steel, with cascade construction.
- » Outer carcass of powder-coated sheet steel.
- » Inner carcass of high-quality decor panels.

Colour:

- » Folding doors in zinc yellow RAL 1018.
- » Carcass completely in light grey RAL 7035.
- » Customised colours possible.

Safety and functionality

Larger quantities of hazardous materials can be stored in a compact space thanks to the Type 90 PREMIUM standard cabinets from DÜPERTHAL, which naturally offer 90 minutes of fire resistance. Enjoy the spacious storage capabilities of the PREMIUM standard safety cabinet from DÜPERTHAL.

Focus on functionality

- 1 Pitch intervals of 32 mm enable variable adjustment of the shelves. All the shelves are mounted on supports to prevent tilting and complete removal.
- 2 The PREMIUM standard safety storage cabinet offers maximum storage capacity with optimal utilisation of the available space.



One-hand folding door technology

Thanks to the tried and tested one-hand folding door mechanism, the doors move with ease and can be easily opened with one hand and minimal effort.



Ordering information

Certified safety of the highest level included:



1.2.1 PREMIUM standard XL – V1 with shelves and centre partition wall

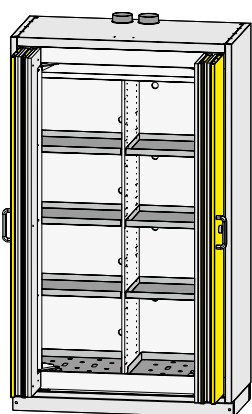

Details

6 shelves, 2 bottom trays, 2 perforated sheet inserts, centre partition wall and base

Fittings and features

	Ref. no.	
	with classic folding door mechanism	with one-hand folding door mechanism
Interior fittings – sheet steel	29-201262-020	29-201264-020
Interior fittings – stainless steel	29-201262-040	29-201264-040

Dimensions [in mm]

	Outer	Inner
Width	1195	1099
Depth	595	446
Height	2080	1830

Max. storage capacity/standing surface

Quantity	Type of container	Size
52	Spray cans	400 ml
19	Cans	1.0 litre
22	Glass laboratory bottles	1.0 litre
9	Glass laboratory bottles	2.5 litres

Weight [in kg] 475

1.2.2 PREMIUM standard XL – V2 with shelves

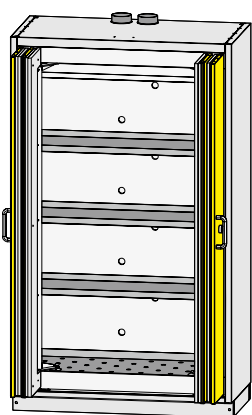

Details

3 shelves, 1 bottom tray, 1 perforated sheet insert and base

Fittings and features

	Ref. no.	
	with classic folding door mechanism	with one-hand folding door mechanism
Interior fittings – sheet steel	29-201262-021	29-201264-021
Interior fittings – stainless steel	29-201262-041	29-201264-041

Dimensions [in mm]

	Outer	Inner
Width	1195	1099
Depth	595	446
Height	2080	1830

Max. storage capacity/standing surface

Quantity	Type of container	Size
105	Spray cans	400 ml
38	Cans	1.0 litre
45	Glass laboratory bottles	1.0 litre
19	Glass laboratory bottles	2.5 litres

Weight [in kg] 475

1.2.3 PREMIUM standard M with shelves

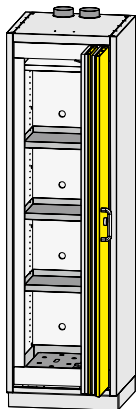

Details

3 shelves, 1 bottom tray, 1 perforated sheet insert and base

Fittings and features

Ref. no.

	Ref. no.	
	with classic folding door mechanism	with one-hand folding door mechanism
Interior fittings – sheet steel	29-200662-021	–
Interior fittings – stainless steel	29-200662-041	–

Dimensions [in mm]

	Outer	Inner
Width	595	499
Depth	595	446
Height	2080	1830

Max. storage capacity/standing surface

Quantity	Type of container	Size
46	Spray cans	400 ml
16	Cans	1.0 litre
20	Glass laboratory bottles	1.0 litre
8	Glass laboratory bottles	2.5 litres

Weight [in kg] 290

1.2.4 PREMIUM standard ML with shelves – special depth 745 mm

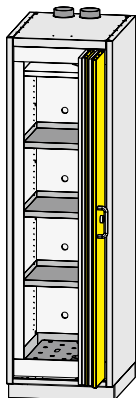

Details

3 shelves, 1 bottom tray, 1 perforated sheet insert and base

Fittings and features

Ref. no.

	Ref. no.	
	with classic folding door mechanism	with one-hand folding door mechanism
Interior fittings – sheet steel	29-200672-021	–
Interior fittings – stainless steel	29-200672-041	–

Dimensions [in mm]

	Outer	Inner
Width	595	499
Depth	745	595
Height	2080	1830

Max. storage capacity/standing surface

Quantity	Type of container	Size
64	Spray cans	400 ml
23	Cans	1.0 litre
27	Glass laboratory bottles	1.0 litre
11	Glass laboratory bottles	2.5 litres

Weight [in kg] 350

For further technical details and dimensions, see page 50.

Accessories PREMIUM standard

Select your preferred laboratory accessories from a wide range of optional extras. Design your working environment individually to suit your exact requirements and procedures.

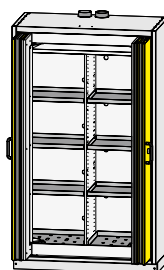

		PREMIUM standard XL – V1	PREMIUM standard XL – V2
Additional interior fittings: Material:			
Shelf	Sheet steel	29-81260-118	29-81260-114
Shelf	Stainless steel	29-81260-218	29-81260-214
Insert for shelf	PP	29-81260-318	29-81260-314
Anti-slip mat	Rubber	29-81260-518	29-81260-514
Pipe penetration (resealable)		29-70000-045	29-70000-045
Pipe penetration		29-70000-048	29-70000-048
Locker (door hinge left)		29-70000-036	29-70000-036
Locker (door hinge right)		29-70000-037	29-70000-037
Red Box		2.233.04	2.233.04
Optional extras:			
Exhaust air system or ventilator			
Safety container			
Absorber			
see page 42 or www.dueperthal.com			

For further technical details and dimensions, see page 50.

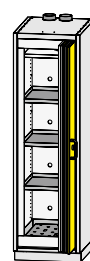
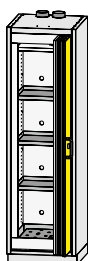

PREMIUM standard M	PREMIUM standard ML
29-80660-114	29-80670-114
29-80660-214	29-80670-214
29-80660-314	29-80670-314
29-80660-514	29-80670-514
29-70000-045	29-70000-045
29-70000-048	29-70000-048
-	-
-	-
2.233.04	2.233.04
see page 42 or www.dueperthal.com	



PREMIUM SL – Type 90

The PREMIUM SL cabinets are a convenient solution for storing different containers. The easy-moving pull-out trays with dual arrest mechanism ensure simple and safe access to the contents of the cabinet.



PREMIUM SL XL – V1



PREMIUM SL XL – V2



PREMIUM SL M – V1



PREMIUM SL ML – V1

Interior fittings:

- » Shelves, bottom trays and perforated sheet inserts either in sheet steel or stainless steel.

Construction:

- » Folding doors of powder-coated sheet steel, with cascade construction.
- » Outer carcass of powder-coated sheet steel.
- » Inner carcass of high-quality decor panels.

Colour:

- » Folding doors in zinc yellow RAL 1018.
- » Carcass completely in light grey RAL 7035.
- » Customised colours possible.

Safety and functionality

The PREMIUM SL safety storage cabinet is the ideal solution for safe and efficient storage of different containers. It has a number of additional features that enhance both safety and working comfort.

Focus on functionality

- 1** Extremely easy-moving folding doors, either with one-hand or classic operation, take up much less room and are therefore particularly suitable for smaller laboratories.
- 2** The pneumatically powered doors mean that they can be easily opened with one hand, without external force.
- 3** A dual arrest mechanism prevents more than one pull-out tray from being pulled out at a time. This prevents accidents, in which cabinets tip over due to a weight shift.
- 4** In case of fire, a thermocouple ensures that the doors are closed automatically. The closure control system ensures that first the pull-out trays are withdrawn into the cabinet before the doors are closed.



1



2

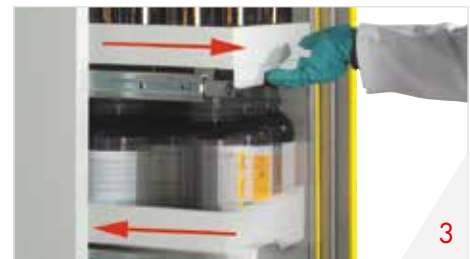

3



4

Further features



5 Ease of operation is enhanced thanks to the ergonomic position of the lock at handle height and a locking cylinder integrated in the door.



6 The cabinet is easy to manoeuvre thanks to the construction of the base, enabling transportation with a pallet truck, for instance.



One-hand folding door technology

Thanks to the tried and tested one-hand folding door mechanism, the doors move with ease and can be easily opened with one hand and minimal effort.



Certified safety of the highest level included:

Ordering information



1.2.5 PREMIUM SL XL – V1 with pull-out trays

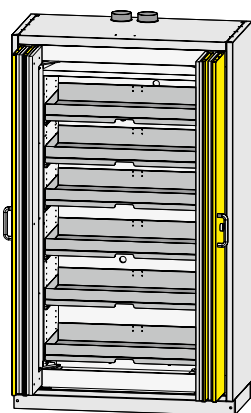

Details

6 pull-out trays V* and base

Fittings and features

Ref. no.

	with classic folding door mechanism	with one-hand folding door mechanism
Interior fittings – sheet steel	29-201262-061	29-201264-061
Interior fittings – stainless steel	29-201262-081	29-201264-081

Dimensions [in mm]

	Outer	Inner
Width	1195	1099
Depth	595	446
Height	2080	1830

Max. storage capacity/standing surface

Quantity	Type of container	Size
77	Spray cans	400 ml
29	Cans	1.0 litre
35	Glass laboratory bottles	1.0 litre
14	Glass laboratory bottles	2.5 litres

Weight [in kg] 475

PREMIUM SL – Type 90

1.2.6 PREMIUM SL XL – V2 with pull-out trays

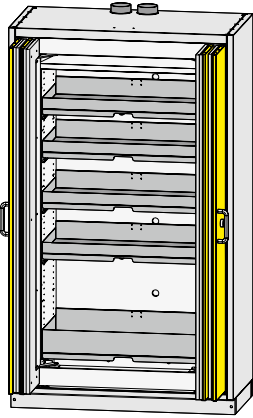

Details

4 pull-out trays V*,
1 pull-out tray E** and base

Fittings and features

Ref. no.

	with classic folding door mechanism	with one-hand folding door mechanism
Interior fittings – sheet steel	29-201262-062	29-201264-062
Interior fittings – stainless steel	29-201262-082	29-201264-082

Dimensions [in mm]

	Outer	Inner
Width	1195	1099
Depth	595	446
Height	2080	1830

Max. storage capacity/standing surface

Quantity	Type of container	Size
77	Spray cans	400ml
29	Cans	1.0 litre
35	Glass laboratory bottles	1.0 litre
14	Glass laboratory bottles	2.5 litres

Weight [in kg] 475

1.2.7 PREMIUM SL XL – V3 with pull-out trays

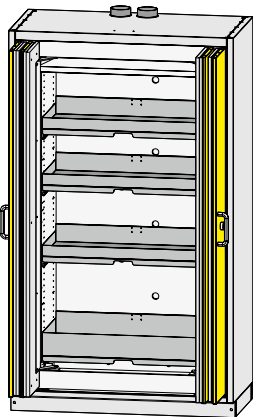

Details

3 pull-out trays V*,
1 pull-out tray E** and base

Fittings and features

Ref. no.

	with classic folding door mechanism	with one-hand folding door mechanism
Interior fittings – sheet steel	29-201262-063	29-201264-063
Interior fittings – stainless steel	29-201262-083	29-201264-083

Dimensions [in mm]

	Outer	Inner
Width	1195	1099
Depth	595	446
Height	2080	1830

Max. storage capacity/standing surface

Quantity	Type of container	Size
77	Spray cans	400ml
29	Cans	1.0 litre
35	Glass laboratory bottles	1.0 litre
14	Glass laboratory bottles	2.5 litres

Weight [in kg] 475

1.2.8 PREMIUM SL XL – V4 with pull-out trays and centre partition wall

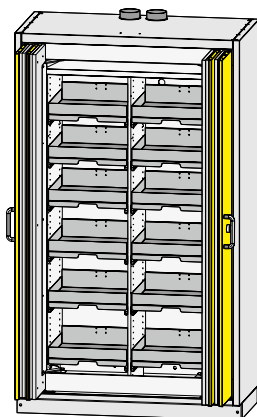

Details

12 pull-out trays V* and base

Fittings and features

Ref. no.

	with classic folding door mechanism	with one-hand folding door mechanism
Interior fittings – sheet steel	29-201262-064	29-201264-064
Interior fittings – stainless steel	29-201262-084	29-201264-084

Dimensions [in mm]

	Outer	Inner
Width	1195	1099
Depth	595	446
Height	2080	1830

Max. storage capacity/standing surface

Quantity	Type of container	Size
37	Spray cans	400ml
13	Cans	1.0 litre
16	Glass laboratory bottles	1.0 litre
6	Glass laboratory bottles	2.5 litres

Weight [in kg] 475

1.2.9 PREMIUM SL XL – V5 with pull-out trays and centre partition wall

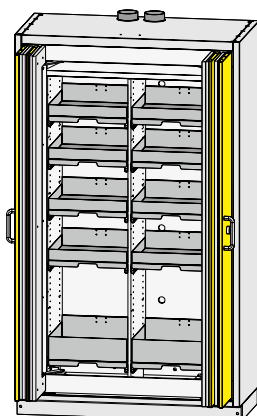

Details

8 pull-out trays V*,
2 pull-out trays E** and base

Fittings and features

Ref. no.

	with classic folding door mechanism	with one-hand folding door mechanism
Interior fittings – sheet steel	29-201262-065	29-201264-065
Interior fittings – stainless steel	29-201262-085	29-201264-085

Dimensions [in mm]

	Outer	Inner
Width	1195	1099
Depth	595	446
Height	2080	1830

Max. storage capacity/standing surface

Quantity	Type of container	Size
37	Spray cans	400ml
13	Cans	1.0 litre
16	Glass laboratory bottles	1.0 litre
6	Glass laboratory bottles	2.5 litres

Weight [in kg] 475

PREMIUM SL – Type 90

1.2.10 PREMIUM SL XL – V6 with pull-out trays and centre partition

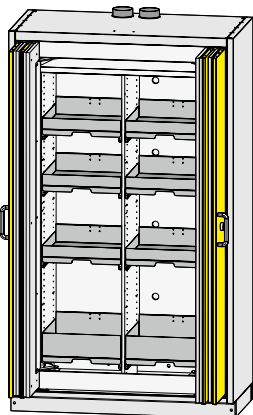

Details

6 pull-out trays V*,
2 pull-out trays E** and base

Fittings and features

Ref. no.

	with classic folding door mechanism	with one-hand folding door mechanism
Interior fittings – sheet steel	29-201262-066	29-201264-066
Interior fittings – stainless steel	29-201262-086	29-201264-086

Dimensions [in mm]

	Outer	Inner
Width	1195	1099
Depth	595	446
Height	2080	1830

Max. storage capacity/standing surface

Quantity	Type of container	Size
37	Spray cans	400ml
13	Cans	1.0 litre
16	Glass laboratory bottles	1.0 litre
6	Glass laboratory bottles	2.5 litres

Weight [in kg] 475

1.2.11 PREMIUM SL XL – V7 with pull-out trays, shelves and centre partition

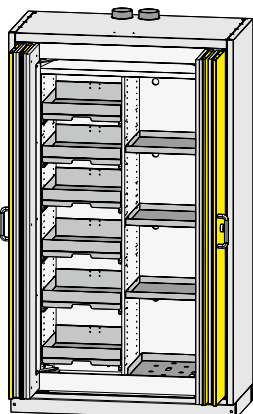

Details

6 pull-out trays V*, 3 shelves, 1 bottom tray,
1 perforated sheet insert and base

Fittings and features

Ref. no.

	with classic folding door mechanism	with one-hand folding door mechanism
Interior fittings – sheet steel	29-201262-067	29-201264-067
Interior fittings – stainless steel	29-201262-087	29-201264-087

Dimensions [in mm]

	Outer	Inner
Width	1195	1099
Depth	595	446
Height	2080	1830

Max. storage capacity/standing surface

Quantity	Type of container	Size
37/53	Spray cans	400ml
13/19	Cans	1.0 litre
16/23	Glass laboratory bottles	1.0 litre
6/9	Glass laboratory bottles	2.5 litres

Weight [in kg] 475

1.2.12 PREMIUM SL XL – V8 with pull-out trays, shelves and centre partition

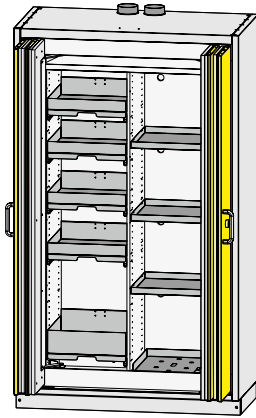

Details

4 pull-out trays V*, 1 pull-out tray E**, 3 shelves,
1 bottom tray, 1 perforated sheet insert and base

Fittings and features

Ref. no.

	with classic folding door mechanism	with one-hand folding door mechanism
Interior fittings – sheet steel	29-201262-068	29-201264-068
Interior fittings – stainless steel	29-201262-088	29-201264-088

Dimensions [in mm]

	Outer	Inner
Width	1195	1099
Depth	595	446
Height	2080	1830

Max. storage capacity/standing surface

Quantity	Type of container	Size
37/53	Spray cans	400ml
13/19	Cans	1.0 litre
16/23	Glass laboratory bottles	1.0 litre
6/9	Glass laboratory bottles	2.5 litres

Weight [in kg] 475

1.2.13 PREMIUM SL XL – V9 with pull-out trays, shelves and centre partition

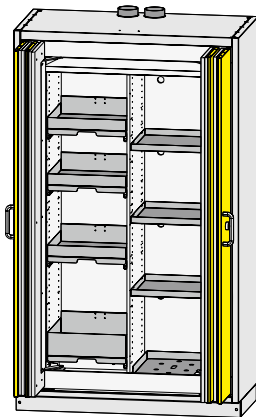

Details

3 pull-out trays V*, 1 pull-out tray E**, 3 shelves,
1 bottom tray, 1 perforated sheet insert and base

Fittings and features

Ref. no.

	with classic folding door mechanism	with one-hand folding door mechanism
Interior fittings – sheet steel	29-201262-069	29-201264-069
Interior fittings – stainless steel	29-201262-089	29-201264-089

Dimensions [in mm]

	Outer	Inner
Width	1195	1099
Depth	595	446
Height	2080	1830

Max. storage capacity/standing surface

Quantity	Type of container	Size
37/53	Spray cans	400ml
13/19	Cans	1.0 litre
16/23	Glass laboratory bottles	1.0 litre
6/9	Glass laboratory bottles	2.5 litres

Weight [in kg] 475

PREMIUM SL – Type 90

1.2.14 PREMIUM SL M – V1 with pull-out trays

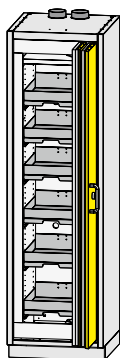

Weight [in kg] 290

Details 6 pull-out trays V* and base

Fittings and features

Interior fittings – sheet steel

Interior fittings – stainless steel

Ref. no.

29-200662-061

29-200662-081

Dimensions [in mm]

	Outer	Inner
Width	595	499
Depth	595	446
Height	2080	1830

Max. storage capacity/standing surface

Quantity	Type of container	Size
46	Spray cans	400 ml
16	Cans	1.0 litre
20	Glass laboratory bottles	1.0 litre
8	Glass laboratory bottles	2.5 litres

1.2.15 PREMIUM SL M – V2 with pull-out trays

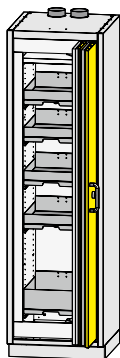

Weight [in kg] 290

Details 4 pull-out trays V*, 1 pull-out tray E** and base

Fittings and features

Interior fittings – sheet steel

Interior fittings – stainless steel

Ref. no.

29-200662-062

29-200662-082

Dimensions [in mm]

	Outer	Inner
Width	595	499
Depth	595	446
Height	2080	1830

Max. storage capacity/standing surface

Quantity	Type of container	Size
46	Spray cans	400 ml
16	Cans	1.0 litre
20	Glass laboratory bottles	1.0 litre
8	Glass laboratory bottles	2.5 litres

1.2.16 PREMIUM SL M – V3 with pull-out trays

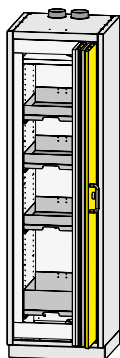

Weight [in kg] 290

Details 3 pull-out trays V*, 1 pull-out tray E** and base

Fittings and features

Interior fittings – sheet steel

Interior fittings – stainless steel

Ref. no.

29-200662-063

29-200662-083

Dimensions [in mm]

	Outer	Inner
Width	595	499
Depth	595	446
Height	2080	1830

Max. storage capacity/standing surface

Quantity	Type of container	Size
46	Spray cans	400 ml
16	Cans	1.0 litre
20	Glass laboratory bottles	1.0 litre
8	Glass laboratory bottles	2.5 litres

1.2.17 PREMIUM SL ML – V1 with pull-out trays – special depth 745 mm

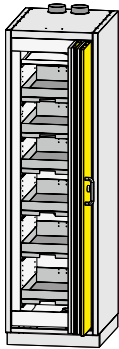

Weight [in kg] 330

Details	6 pull-out trays V* and base	
Fittings and features	Ref. no.	
Interior fittings – sheet steel	29-200672-061	
Interior fittings – stainless steel	29-200672-081	
Dimensions [in mm]	Max. storage capacity/standing surface	
	Outer	Inner
Width	595	499
Depth	745	595
Height	2080	1830
	Quantity	Type of container
	50	Spray cans
	15	Cans
	19	Glass laboratory bottles
	7	Glass laboratory bottles
		Size
		400 ml
		1.0 litre
		1.0 litre
		2.5 litres

1.2.18 PREMIUM SL ML – V2 with pull-out trays – special depth 745 mm

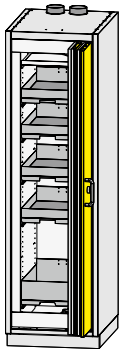

Weight [in kg] 330

Details	4 pull-out trays V*, 1 pull-out tray E** and base	
Fittings and features	Ref. no.	
Interior fittings – sheet steel	29-200672-062	
Interior fittings – stainless steel	29-200672-082	
Dimensions [in mm]	Max. storage capacity/standing surface	
	Outer	Inner
Width	595	499
Depth	745	595
Height	2080	1830
	Quantity	Type of container
	50	Spray cans
	16	Cans
	19	Glass laboratory bottles
	7	Glass laboratory bottles
		Size
		400 ml
		1.0 litre
		1.0 litre
		2.5 litres

1.2.19 PREMIUM SL ML – V3 with pull-out trays – special depth 745 mm

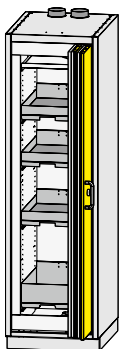

Weight [in kg] 330

Details	3 pull-out trays V*, 1 pull-out tray E** and base	
Fittings and features	Ref. no.	
Interior fittings – sheet steel	29-200672-063	
Interior fittings – stainless steel	29-200672-083	
Dimensions [in mm]	Max. storage capacity/standing surface	
	Outer	Inner
Width	595	499
Depth	745	595
Height	2080	1830
	Quantity	Type of container
	50	Spray cans
	15	Cans
	19	Glass laboratory bottles
	7	Glass laboratory bottles
		Size
		400 ml
		1.0 litre
		1.0 litre
		2.5 litres

Accessories PREMIUM SL XL

Select your preferred laboratory accessories from a wide range of optional extras. Design your working environment individually to suit your exact requirements and procedures.

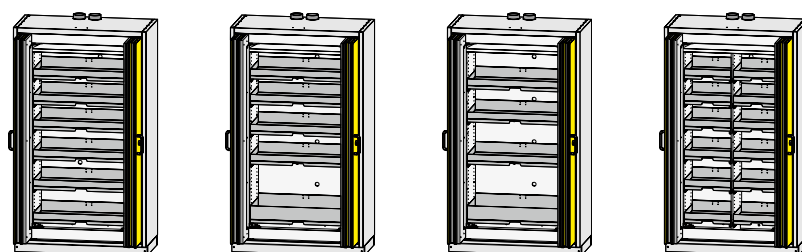

		PREMIUM SL XL – V1	PREMIUM SL XL – V2	PREMIUM SL XL – V3	PREMIUM SL XL – V4
Additional interior fittings:	Material:				
Tray insert V*	PP	29-81262-362	29-81262-362	29-81262-362	29-81262-316
Tray insert E**	PP	–	29-81262-363	29-81262-363	–
Insert for shelf	PP	–	–	–	–
Anti-slip mat for pull-out tray	Rubber	29-81262-562	29-81262-562	29-81262-562	29-81262-516
Anti-slip mat for shelf	Rubber	–	–	–	–
Pipe penetration (resealable)		29-70000-045	29-70000-045	29-70000-045	29-70000-045
Pipe penetration		29-70000-048	29-70000-048	29-70000-048	29-70000-048
Locker (door hinge left)		–	–	–	–
Locker (door hinge right)		–	–	–	–
Red Box		2.233.04	2.233.04	2.233.04	2.233.04
Optional extras:					
Exhaust air system or ventilator					
Safety container					see page 42 or www.dueperthal.com
Absorber					

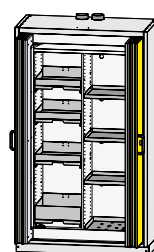
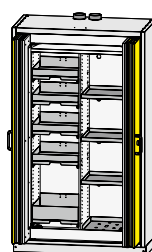
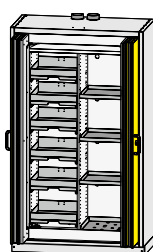
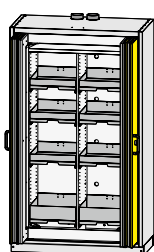
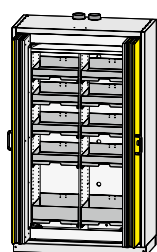

PREMIUM SL XL – V5	PREMIUM SL XL – V6	PREMIUM SL XL – V7	PREMIUM SL XL – V8	PREMIUM SL XL – V9
29-81260-316	29-81262-316	29-81262-316	29-81262-316	29-81262-316
29-81262-317	29-81262-317	–	29-81262-317	29-81262-317
–	–	29-81260-318	29-81260-318	29-81260-318
29-81262-516	29-81262-516	29-81262-516	29-81262-516	29-81262-516
–	–	29-81260-518	29-81260-518	29-81260-518
29-70000-045	29-70000-045	29-70000-045	29-70000-045	29-70000-045
29-70000-048	29-70000-048	29-70000-048	29-70000-048	29-70000-048
–	–	–	–	–
–	–	29-70000-037	29-70000-037	29-70000-037
2.233.04	2.233.04	2.233.04	2.233.04	2.233.04

see page 42 or www.dueperthal.com

Accessories PREMIUM SL M – ML

Select your preferred laboratory accessories from a wide range of optional extras. Design your working environment individually to suit your exact requirements and procedures.

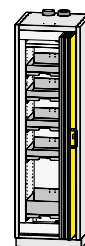
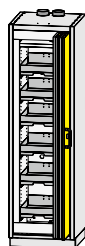

		PREMIUM SL M – V1	PREMIUM SL M – V2
Additional interior fittings:	Material:		
Tray insert V*	PP	29-80662-316	29-80662-316
Tray insert E**	PP	–	29-80662-317
Insert for shelf	PP	–	–
Anti-slip mat for pull-out tray	Rubber	29-80662-516	29-80662-516
Anti-slip mat for shelf	Rubber	–	–
Pipe penetration (resealable)		29-70000-045	29-70000-045
Pipe penetration		29-70000-048	29-70000-048
Locker (door hinge left)		–	–
Locker (door hinge right)		–	–
Red Box		2.233.04	2.233.04
Optional extras:			
Exhaust air system or ventilator			
Safety container			see page 42 or www.dueperthal.com
Absorber			

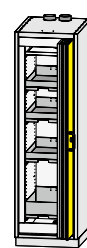
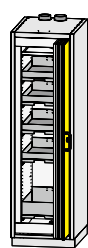
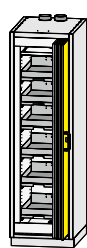
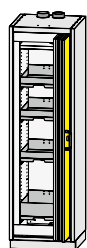

PREMIUM SL M – V3	PREMIUM SL ML – V1	PREMIUM SL ML – V2	PREMIUM SL ML – V3
29-80662-316	29-80672-316	29-80672-316	29-80672-316
29-80662-317	–	29-80672-317	29-80672-317
–	–	–	–
29-80662-516	29-80672-516	29-80672-516	29-80672-516
–	–	–	–
29-70000-045	29-70000-045	29-70000-045	29-70000-045
29-70000-048	29-70000-048	29-70000-048	29-70000-048
–	–	–	–
–	–	–	–
2.233.04	2.233.04	2.233.04	2.233.04

see page 42 or www.dueperthal.com



PREMIUM vario – Type 90

Type 90 PREMIUM vario cabinets are particularly suitable for storing hazardous substances in smaller containers. Containers are readily accessible on opening the easy-moving folding doors.



PREMIUM vario XL



PREMIUM vario M

Interior fittings:

- » Sheet steel vario shelves.

Construction:

- » Folding doors of powder-coated sheet steel, with cascade construction.
- » Outer carcass of powder-coated sheet steel.
- » Inner carcass of high-quality decor panels.

Colour:

- » Folding doors in zinc yellow RAL 1018.
- » Carcass completely in light grey RAL 7035.
- » Customised colours possible.

Safety and functionality

The Type 90 PREMIUM vario safety storage cabinet permits quick access to small containers using a space-saving door-opening mechanism. This makes PREMIUM vario the ideal safety storage cabinet, also for smaller laboratories.

Focus on functionality

- 1** Pitch intervals of 64 mm enable flexible, individual adjustment of all the vario shelves.
- 2** All doors have an integrated arrest system, allowing containers to be removed from the cabinet and replaced with both hands.
- 3** On closing the doors, the containers slide back into the cabinet with the help of an intelligent closing mechanism.
- 4** In case of fire, a thermocouple ensures that the doors are closed automatically.



Further features



5 Equipotential bonding saddles are a standard feature for earthing the cabinet in accordance with TRBS 2153 (to avoid risks of ignition). The interior is conductively connected to the equipotential bonding saddles.



6 Ease of operation is enhanced thanks to the ergonomic position of the lock at handle height and a locking cylinder integrated in the door.



7 The cabinet is easy to manoeuvre thanks to the construction of the base, enabling transportation with a pallet truck, for instance.

Certified safety of the highest level included:

Ordering information



1.2.20 PREMIUM vario XL with vario shelves

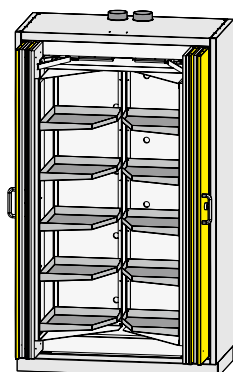

Details

10 vario shelves and base

Fittings and features

Interior fittings – sheet steel

Ref. no.

29-201262-051

Dimensions [in mm]

	Outer	Inner
Width	1195	1099
Depth	595	446
Height	2080	1830

Max. storage capacity/standing surface

Quantity	Type of container	Size
36	Spray cans	400 ml
12	Cans	1.0 litre
28	Glass laboratory bottles	0.5 litre
16	Glass laboratory bottles	1.0 litre
6	Glass laboratory bottles	2.5 litres

Weight [in kg] 475

1.2.21 PREMIUM vario M with vario shelves

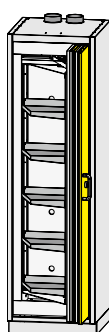

Details

5 vario shelves and base

Fittings and features

Interior fittings – sheet steel

Ref. no.

29-200662-051

Dimensions [in mm]

	Outer	Inner
Width	595	499
Depth	595	446
Height	2080	1830

Max. storage capacity/standing surface

Quantity	Type of container	Size
36	Spray cans	400 ml
12	Cans	1.0 litre
28	Glass laboratory bottles	0.5 litre
16	Glass laboratory bottles	1.0 litre
6	Glass laboratory bottles	2.5 litres

Weight [in kg] 290

Accessories PREMIUM vario

Select your preferred laboratory accessories from a wide range of optional extras. Design your working environment individually to suit your exact requirements and procedures.



Lock release with RFID card
The PREMIUM line is ideally suited for use with the RFID card with MPS-1.



Anti-slip mat
Anti-slip mats can prevent containers from inadvertently slipping. Hence, everything remains exactly where it should be.



Exhaust air systems
Exhaust air control systems help safeguard workplaces at risk of explosion. An integrated exhaust air monitoring unit emits an alarm in the event of failure (also available with optional ventilator).



Absorber cloths
If something is spilled, absorber cloths are a safe way to mop up hazardous substances.

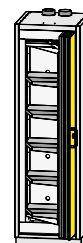
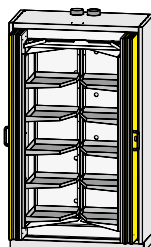

		PREMIUM vario XL	PREMIUM vario M
Additional interior fittings:	Material:		
Tray insert V*	PP	–	–
Tray insert E**	PP	–	–
Insert for shelf	PP	–	–
Anti-slip mat for pull-out tray	Rubber	–	–
Anti-slip mat for vario shelves	Rubber	29-81266-550	29-81266-550
Pipe penetration (resealable)		–	–
Pipe penetration		–	–
Locker (door hinge left)		–	–
Locker (door hinge right)		–	–
Red Box		2.233.04	2.233.04
Optional extras:			
Exhaust air system or ventilator		see page 42 or www.dueperthal.com	
Safety container			
Absorber			

Exhaust air systems and ventilators



To guarantee maximum safety for your employees, connection to exhaust air systems is essential in the case of many chemicals. DÜPERTHAL offers a variety of solutions to stop harmful vapours escaping into the working area. All ventilators and components comply with Directive 94/9/EC (ATEX) and thus meet the highest safety standards.

» Exhaust air systems

» Filter systems

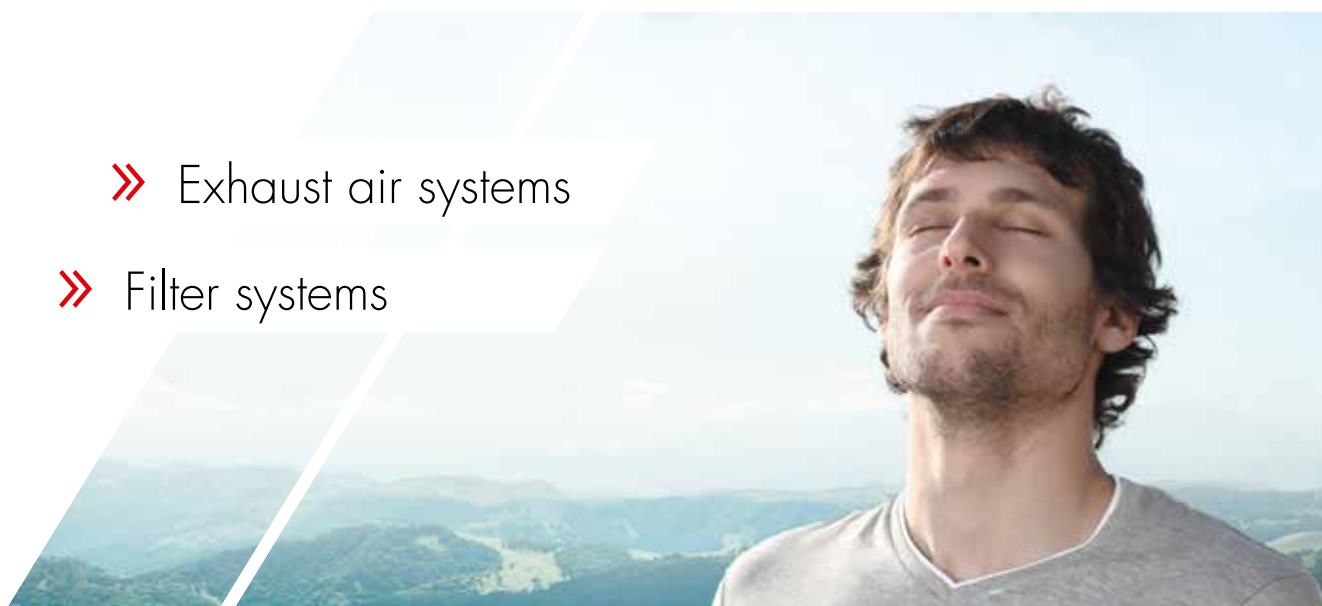

Exhaust air systems



The exhaust air monitor with ventilator is designed for straightforward ventilation and monitoring of safety storage cabinets. A sensor controls the flow of air and emits optical and acoustic alarms if the required value is not reached. The complete exhaust air monitoring unit is pre-assembled on delivery for mounting directly on the cabinet.

Filter systems



Our filter systems are suitable for ventilating and monitoring safety storage cabinets stocked with solvents. They filter almost 100% of any harmful hydrocarbons by means of molecular adsorption, thereby providing users with optimal protection. Additional connection to an exhaust air system is not necessary.

Visit our website for more information on exhaust air systems and other accessories: www.dueperthal.com

More detailed information on the requirements, construction and technical specifications of the ventilation systems we supply for your safety storage cabinets can be found here.



ATEX-compliant
Directive 94/9/EC

⊕ II (3) G c IIB T4

⊕ II (3) G [n4]



Exhaust air monitor with ventilator

Filter unit with ventilator



The many advantages of the DÜPERTHAL exhaust air systems and filter systems

- » ATEX conformity as per Directive 94/9/EC and type certificate from TÜV Süd.
- » Modern “blue mode” LED display with choice of languages: English, French or German.
- » Pre-assembled on delivery for easy installation.
- » Particularly quiet thanks to high-quality finishing.

Ordering information exhaust air systems

Tested safety at a very high level including:

ATEX  **DIN EN CE**

4.1.1 Exhaust air monitor with ventilator



Details

For easy ventilation and monitoring of safety storage cabinets. A sensor monitors the air stream and gives a visual and audible signal if the value drops below the required value. The complete exhaust air monitoring unit including the integrated ventilator is supplied pre-assembled and is placed directly onto the cabinet. The required value for the air stream flow rate is factory-preset and can be adjusted individually using the pressure difference socket. The housing is made of powder-coated sheet steel, silver pearl glimmer.

- » The exhaust air rate can be adjusted electronically to suit all cabinet sizes.
- » ATEX conformity in accordance with directive 94/9/EC and type certificate by TÜV Süd.
- » An air flow sensor monitors the actual exhaust air flow rate – the complete ventilation system of the cabinet is monitored.
- » Monitoring of the volumetric flow rate and the power supply.
- » Optical and acoustic warning when the exhaust air flow rate falls below the set value.
- » Including two floating contacts (24V/2A) for signal transmission to an external control centre.
- » In case of a power failure, an internal accumulator buffers the monitoring systems for four hours, display with simple fault indication.
- » Model ready to plug in, thus easy to assemble.
- » Memory of the last 50 error messages including date, time, type of error and change of menu.
- » Modern LED-Display "Blue Mode" with language options German, English or French.
- » The exhaust air monitoring function can be switched off.
- » Ventilator according to DIN EN 14986 – low noise level
- » Constant monitoring in accordance with DIN EN 1946-7.

Ref. no.	2.00.320
-----------------	----------

Dimensions [in mm]

Width	250
Depth	318
Height	352

Technical data

Ø collar	mm	75
Volumetric flow rate*	m ³ /h	0 – 72
RPM*	l/min	0 – 2820
Voltage/frequency	V/Hz	230/50
Current consumption	A	0,1
Noise level	db	34 – 56

*gradual, without resistance

4.1.2 Exhaust air monitor without ventilator



Details

For easy monitoring of the ventilation of safety storage cabinets. A sensor monitors the air stream and gives a visual and audible signal if the value drops below the required value. The complete exhaust air monitoring unit is supplied pre-assembled and is placed directly onto the cabinet. The required value for the air stream flow rate is factory-preset and can be adjusted individually using the pressure difference socket. The housing is made of powder-coated sheet steel, silver pearl glimmer.

- › ATEX conformity in accordance with directive 94/9/EC and type certificate by TÜV Süd.
- › An air flow sensor monitors the actual exhaust air flow rate – the complete ventilation system of the cabinet is monitored.
- › Monitoring of the volumetric flow rate and the power supply.
- › Optical and acoustic warning when the exhaust air flow rate falls below the set value.
- › Including two floating contacts (24V/2A) for signal transmission to an external control centre.
- › In case of a power failure, an internal accumulator buffers the monitoring systems for four hours, display with simple fault indication.
- › Model ready to plug in, thus easy to assemble.
- › Memory of the last 50 error messages including date, time, type of error and change of menu.
- › Modern LED-Display "Blue Mode" with language options German, English or French.
- › The exhaust air monitoring function can be switched off.
- › Constant monitoring in accordance with DIN EN 1946-7.

Ref. no.	2.00.360		
Dimensions [in mm]	Technical data		
Width	210	Ø collar	mm 75
Depth	210	Voltage/frequency	V/Hz 230/50
Height	215	Current consumption	A 0,1

4.1.3 Ventilation unit with ventilator



Details

For easy ventilation of safety storage cabinets. The ventilation unit including the integrated ventilator is supplied pre-assembled and is placed directly onto the cabinet. The housing is made of powder-coated sheet steel, silver pearl glimmer.

- › ATEX conformity in accordance with directive 94/9/EC and type certificate by TÜV Süd.
- › Model ready to plug in, thus easy to assemble.
- › Ventilator according to DIN EN 14986 – low noise level.

Ref. no.	2.00.339		2.00.340	
Dimensions [in mm]	Technical data			
Width	250	Ø collar	mm 75	75
Depth	318	Volumetric flow rate**	m ³ /h 72	60
Height	352	RPMI**	1/min 2600	1200
		Voltage/frequency	V/Hz 230/50	230/50
		Current consumption	A 0,1	0,1
		Noise level	db 56	37

**without resistance

Ordering information filter systems

4.2.1 Filter unit with ventilator



Details

For ventilation and monitoring of safety cabinets through nearly 100% filtering of harmful vapours of solvents (hydrocarbons) by molecular adsorption. The filtering provides optimal protection of the users. An additional exhaust connection is not required, therefore the filter unit can be positioned directly on top or beside the cabinet and can be started to run. The cleaned air is released to the room, without consuming heated or conditioned air. A sensor monitors the air stream and gives a visual and audible signal if the value drops below the programmed value. The housing is made of powder-coated sheet steel, silver pearl glimmer.

- › The exhaust air rate can be adjusted electronically to suit all cabinet sizes.
- › ATEX conformity in accordance with directive 94/9/EC and type certificate by TÜV Süd.
- › Fulfil the requirements of modern laboratories "green labs" with highest flexibility of installation.
- › **Multistage, earthed filter system with safety of factor 2 – consists of:**
 - 2 x activated carbon filters for extremely high efficiency of the filtration – almost 100%.
 - additional particle filter in accordance with DIN EN 779.
- › **Multistage filter warning system:**
 - Pressure difference monitoring adjustable.
 - Filter elements and cover of filter monitored by microswitches.
 - Time function, up to the next maintenance – in acc. with DIN 12927 and EN 13463.
 - filter change is necessary annually.
 - 3-months-check of the activated carbon filters by the user – monitored through input protocol and time function.
- › List of filterable substances.
- › Warning system with fault indication in case of ventilator failure.
- › Electronic logging of the error messages.
- › Two floating contacts (24V/2A) for signal transmission.
- › Modern LED-Display "Blue Mode" with language options German, English or French.
- › Model ready to plug in, thus easy to assemble.
- › Fulfills the requirements of TRGS 510, DGUV regulation 1 and TRBS 2153.
- › Ventilator according to DIN EN 14986.

Accessories

Activated carbon filter	2.00.391*
Particle filter	2.00.392*
Filter set (activated carbon and particle filter)	2.00.393*

Ref. no.

2.00.390*

Dimensions [in mm]

Width	530
Depth	440
Height	270

Technical data

Ø collar	mm	75
Volumetric flow rate*	m ³ /h	0 – 37
RPM*	1/min	0 – 2820
Voltage/frequency	V/Hz	230/50
Current consumption	A	0,1
Noise level	db	38 – 56

*gradual, without resistance

Tested safety at a very high level including:

ATEX DIN EN CE

4.2.2 Filter unit with ventilator



Details

For ventilation and monitoring of safety cabinets through nearly 100% filtering of harmful vapours of solvents (hydrocarbons) by molecular adsorption. The filtering provides optimal protection of the users. An additional exhaust connection is not required, therefore the filter unit can be positioned directly on top or beside the cabinet and can be started to run. The cleaned air is released to the room, without consuming heated or conditioned air. A sensor monitors the air stream and gives a visual and audible signal if the value drops below the programmed value. The housing is made of powder-coated sheet steel, silver pearl glimmer.

- › Super silent ventilator for especially low noise emission.
- › ATEX conformity in accordance with directive 94/9/EC.
- › Fulfil the requirements of modern laboratories "green labs" with highest flexibility of installation.
- › **Multistage, earthed filter system with safety of factor 2 – consists of:**
 - 2 x activated carbon filters for extremely high efficiency of the filtration – almost 100%.
 - additional particle filter in accordance with DIN EN 779.
- › **Multistage filter warning system:**
 - Filter elements and cover of filter monitored by microswitches.
 - Time function, up to the next maintenance – in acc. with DIN 12927 and EN 13463.
 - filter change is necessary annually.
 - 3-months-check of the activated carbon filters by the user – monitored through input protocol and time function.
- › List of filterable substances.
- › Warning system with fault indication in case of ventilator failure.
- › Floating contact (24V/2A) for signal transmission.
- › LED display for function control.
- › Model ready to plug in, thus easy to assemble.
- › Fulfils the requirements of TRGS 510, DGUV regulation 1 and TRBS 2153.
- › Ventilator according to DIN EN 14986.
- › Constant monitoring in accordance with DIN EN 1946-7.

Accessories

Activated carbon filter	2.00.391*
Particle filter	2.00.392*
Filter set (activated carbon and particle filter)	2.00.393*

Ref. no.

2.00.397*

Dimensions [in mm]

Width	550
Depth	445
Height	275

Technical data

Ø collar	mm	75
Volumetric flow rate*	m ³ /h	24
Voltage/frequency	V/Hz	230/50
Power	W	26
Noise level	db	43

Safety containers for hazardous liquids

Safety containers not only facilitate handling, but also enhance occupational safety when it comes to managing hazardous substances. DÜPERTHAL safety containers comply with various requirements, such as the test standards for occupational safety, the German Equipment and Product Safety Act (GPSG) and the Technical Rules for Hazardous Substances (TRGS). The wide range of containers cover a multitude of uses, ensuring that hazardous liquids can be handled with confidence. They are made of different materials, such as sheet steel, stainless steel or plastic, and offer maximum media resistance. As a guarantee of safety in the public transportation of hazardous substances, the transport vessels have also been tested in accordance with ADR/RID and IMDG, and in some cases ICAO-TI.



A variety of containers for hazardous liquids

Whether the container is intended for distribution, collection or dispensing, DÜPERTHAL safety containers simplify the process of handling hazardous liquids and thus make an important contribution to occupational safety. Whether you work with acids, lye or flammable materials, these containers leave you completely in control.

Visit our website for more information on safety containers and other accessories: www.dueperthal.com

More detailed information on the requirements, construction and technical specifications of our entire range of safety containers can be found here.



Optimised for safe handling

- » Thoroughly resistant to media.
- » Container labelling as per the German Hazardous Substances Ordinance (GefStoffV) and Workplace Directive A1.3 (ASR).
- » All products have been manufactured to the latest technological standards, technical safety requirements and relevant specifications.

Technical specifications PREMIUM standard – Type 90

Technical details		Model size			
		M	ML	XL with centre partition	XL without
Load bearing capacity with uniformly distributed load (maximum load capacity/shelf)	in kg	75	75	75	75
Maximum volume of the largest single container that may be placed on the standing surface of the cabinet	in L	12	16	21	46
Collection volume of bottom tray	in L	14	18	24	51
Volumetric flow rate for 10-fold air exchange	in m ³ /h (approx.)	4	6	10	10
Pressure drop in cabinet	in Pa	<1	<1	<1	<1

Dimensions – interior fittings [in mm]				Model size								
				M			ML			XL with centre partition		
	Width	Depth	Height	Width	Depth	Height	Width	Depth	Height	Width	Depth	Height
Shelf	490	430	35	490	580	35	536	430	35	1090	430	35
Bottom tray	485	440	65	485	590	65	523	440	126	1085	440	126
Perforated sheet insert	432	422	80	432	572	80	515	422	126	1067	422	126

Front view	Side view	Top view
------------	-----------	----------

PREMIUM XL

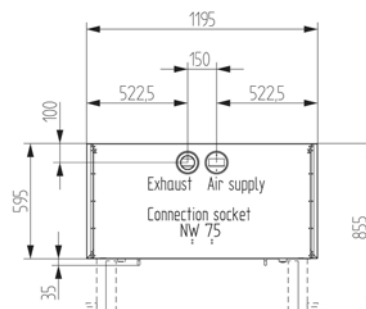
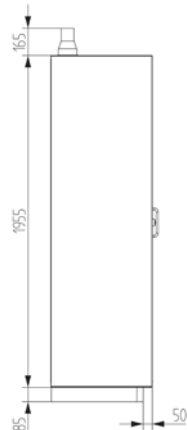
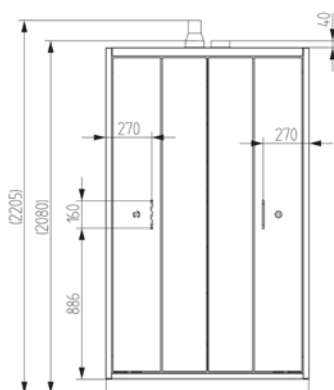

PREMIUM M

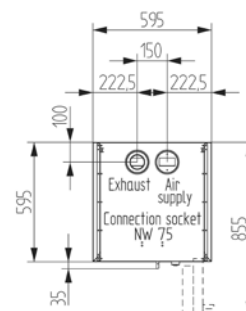
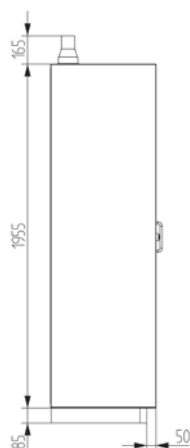
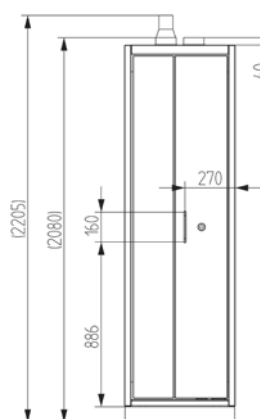

PREMIUM ML

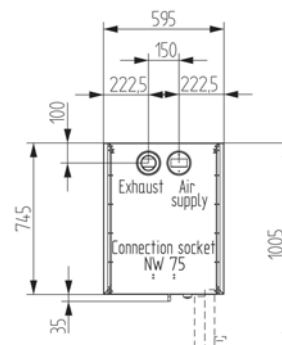
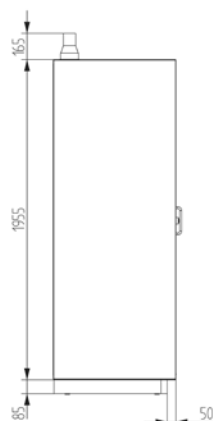
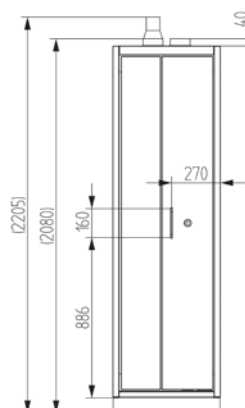

Technical specifications PREMIUM SL – Type 90

Technical details			Model size			
			M	ML	XL with centre partition	XL without centre partition
Load bearing capacity with uniformly distributed load (maximum load capacity/shelf)	in kg	Pull-out tray V*	30	30	30	60
		Pull-out tray E**	50	50	50	60
		Shelf	–	–	75	–
Maximum volume of the largest single container that may be placed on the standing surface of the cabinet	in L	Pull-out tray V*	7	10	9	19
		Pull-out tray E**	15	21	19	39
		Shelf with bottom tray	–	–	13	–
Collection volume	in L	Pull-out tray V*	8	11	10	21
		Pull-out tray E**	17	23	21	43
		Bottom tray	–	–	14	–
Volumetric flow rate for 10-fold air exchange	in m ³ /h (approx.)	–	4	6	10	10
Pressure drop in cabinet	in Pa	–	<1	<1	<1	<1

	Dimensions – interior fittings [in mm]											
	M			ML			XL with centre partition			XL without centre partition		
	Width	Depth	Height	Width	Depth	Height	Width	Depth	Height	Width	Depth	Height
Pull-out tray V*	339	410	60	339	560	60	420	410	60	862	410	60
Pull-out tray E**	339	410	124	339	560	124	420	410	124	862	410	124
Shelf	–			–			536	430	35	–		
Bottom tray	–			–			523	440	126	–		
Perforated sheet insert	–			–			515	422	126	–		

Adjustable heights PREMIUM SL [in mm]					
6 pull-out trays		5 pull-out trays		4 pull-out trays	
V*	202	V*	202	V*	292
V*	199	V*	199	V*	269
V*	199	V*	239	V*	349
V*	239	V*	239	V*	499
V*	239	V*		V*	
E**	269	E**	499	E**	499

Container heights	
Type of container	Height
0.5 litre glass laboratory bottle	195 mm
1.0 litre glass laboratory bottle	235 mm
2.5 litre glass laboratory bottle	265 mm
12.0 litre combination container	345 mm
12.0 litre combination container (with high funnel)	490 mm

Other adjustable heights available on request.

*V = for small containers of 0.5 – 2.5 litres

**E = for larger containers, e.g. 12 litres

Front view

Side view

Top view

PREMIUM XL

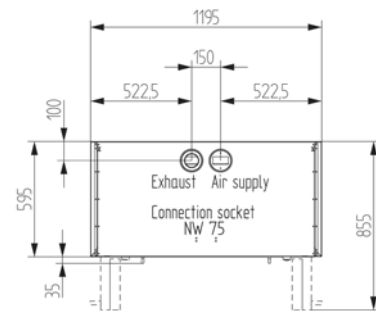
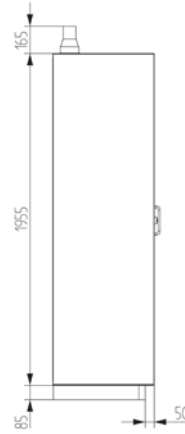
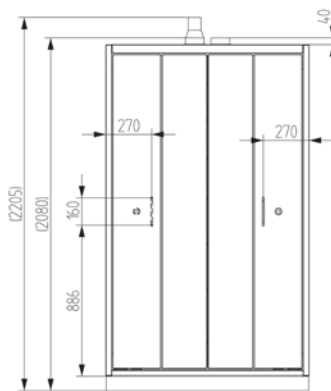

PREMIUM M

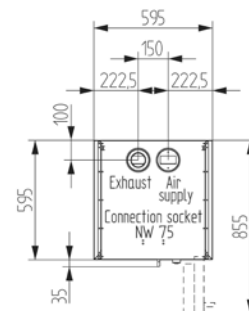
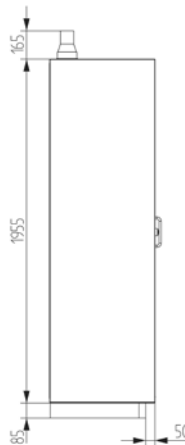
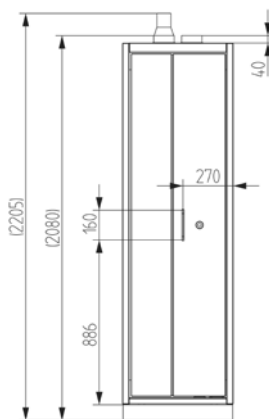

PREMIUM ML

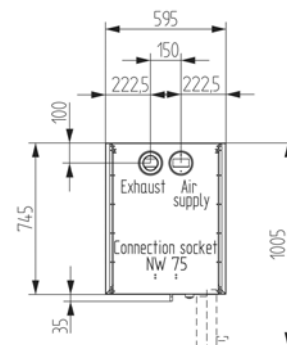
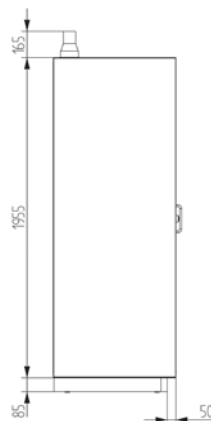
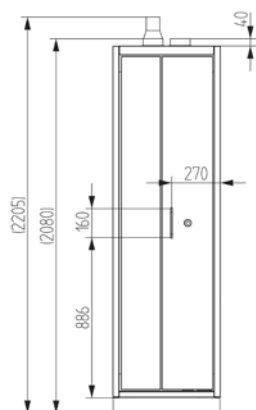

Technical specifications PREMIUM vario – Type 90

Technical details		Model size	
		M	XL
Load bearing capacity with uniformly distributed load (maximum load capacity/shelf)	in kg	22	22
Maximum volume of the largest single container that may be placed on the standing surface of the cabinet	in l	4.3	4.3
Collection volume of vario shelf	in l	4.75	4.75
Volumetric flow rate for 10-fold air exchange	in m ³ /h (approx.)	4	10
Pressure drop in cabinet	in Pa	<1	<1

Dimensions – interior fittings [in mm]	Model size					
	M			XL		
	Width	Depth	Height	Width	Depth	Height
Vario shelf	521	402	50	521	402	50

Front view	Side view	Top view
------------	-----------	----------

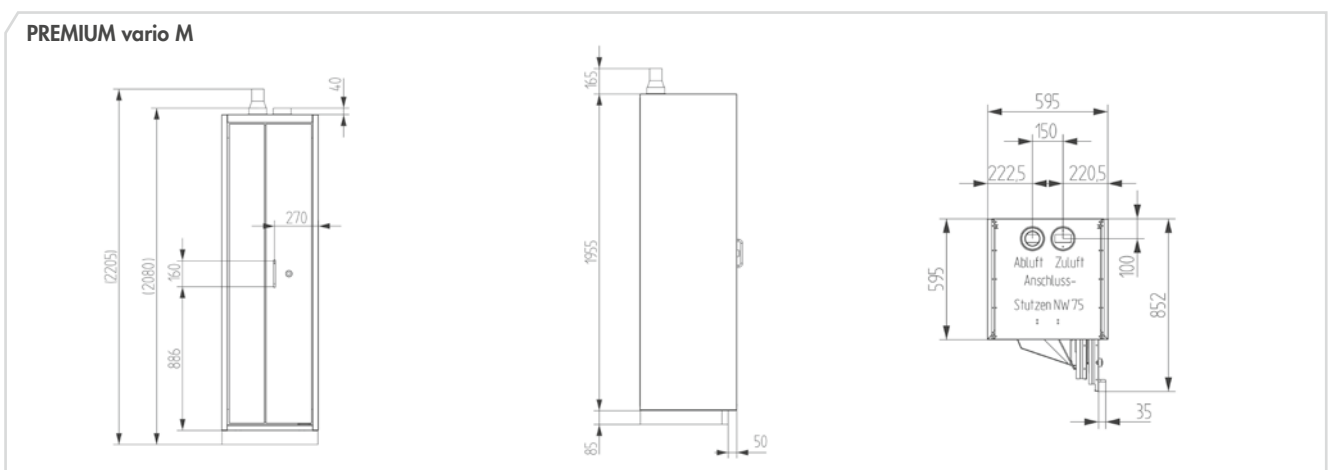
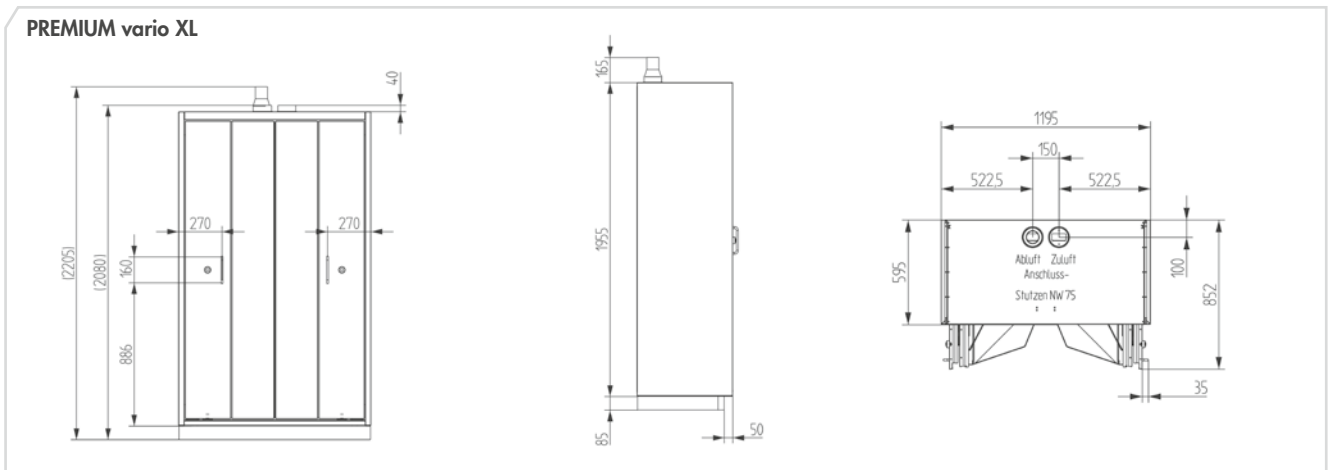

Intelligent technology – Great service

There is more to safety than simply buying a safety storage cabinet. This is why we offer you our certified knowledge, comprehensive service and expertise – supporting you before, during and especially after your decision to buy a DÜPERTHAL safety storage cabinet. For a reassuring feeling of having done everything within your power.

Individual advice.
Intelligent solutions.
Safety requires experts.

Your contact person – for Germany

Phone: +49 6188 9139-0
E-mail: vkid@dueperthal.com

Your contact person – for all other countries

Phone: +49 6188 9139-150
E-mail: export@dueperthal.com

Preventive inspections.
Sustainable maintenance.
Our service sets new standards.

Your contact person – Technical Service

Phone: +49 6188 9139-166
E-mail: service@dueperthal.com



Safety means responsibility.

DÜPERTHAL is one of the leading manufacturers of safety storage cabinets. There are good reasons for choosing DÜPERTHAL safety technology. Find out more about us and our entire product range on www.dueperthal.com.

We look forward to your call!

Mondays to Thursdays from 8.00 am to 5.00 pm
Fridays from 8.00 am to 4.00 pm

DÜPERTHAL Sicherheitstechnik GmbH & Co. KG
Frankenstrasse 3 | 63791 Karlstein | Germany



DÜPERTHAL Sicherheitstechnik GmbH & Co. KG
Frankenstrasse 3 | 63791 Karlstein | Germany
Phone +49 6188 9139-0 | Fax +49 6188 9139-121
info@dueperthal.com | www.dueperthal.com